

- Full 60 MHz uplink (Rx) bandwidth
- **Lowest Noise Figure on the market**
- **AISGv2.0** and current dump compatible (firmware upgradable)
- AISG connector for external RET antenna control by coaxial feeder
- Hardware & software configurable using AISG "personality" upload
- Useable in any orientation

## TTA-UMG000Z\*

**UMTS2100 Twin MHA**  
**60 MHz BW, Dual Duplex**



**Version 2.0**

\* **Model number options:** **Z** indicates different configurations (see next page).

**Variants:** TTA-UMG010Z and TTA-UMG100Z are described on next page.

Electrical Specifications	
<b>Downlink (TX) Path</b>	
Frequency Band	2110 – 2170 MHz
Insertion Loss	0.4 dB max
Insertion loss variation	0.2 dB max across pass band
Return Loss, all ports	18 dB min (VSWR < 1.3)
TX filter rejection in RX band	50 dB min
Rejection @ 920 – 960 MHz	> 75 dBc
Rejection @ 1805 – 1880 MHz	> 65 dBc
Rejection @ 2010 – 2025 MHz	> 25 dBc
Rejection @ 2400 – 2700 MHz	> 65 dBc
Rejection @ 2700 – 2900 MHz	> 75 dBc
Group delay variation per 5 MHz	5 ns max
Continuous Average Power	100 W max.
Peak Envelope Power	1000 W max (at sea level)
Intermodulation, 2x 43 dBm Tx Carriers, BTS port	-120 dBm max. in Rx band, BTS port
<b>Uplink (RX) Path (LNA Mode)</b>	
Frequency Band	1920 – 1980 MHz
Gain	12 ± 1 dB
Gain variation versus frequency	± 0.3 dB max.
Noise Figure	1.1 dB typ., 1.4 dB max at 25 deg C, 1.6 dB max at 60 deg C
Return Loss, normal mode, all ports	18 dB min (VSWR < 1.3)
Rejection in RX input filter @ 2110 – 2170 MHz	> 65 dBc
Rejection @ 920 – 960 MHz	> 75 dBc
Rejection @ 1805 – 1880 MHz	> 65 dBc
Rejection @ 2010 – 2025 MHz	> 25 dBc
Rejection @ 2400 – 2700 MHz	> 65 dBc
Rejection @ 2700 – 2900 MHz	> 75 dBc
Group delay variation per 5 MHz	10 ns max
Output Intercept Point	+18 dBm min.
Maximum Input Power with no damage	+12 dBm
<b>Uplink (RX) Path (Bypass Mode)</b>	
Bypass is the default mode for each channel when not powered.	
Insertion Loss, Bypass mode	3.5 dB max
Return Loss, Bypass mode, all ports	14 dB min
<b>Power Supply and Alarm</b>	
DC Supply Voltage via BTS-RF cable	+9 to +30 V DC
<b>Current Alarm mode (default mode)</b>	
<i>Z in the model number specifies the alarm currents by Node-B type. See table next page.</i>	
The MHA is configured so that each BTS port is individually powered and monitored. Each BTS port sources additional current to indicate any alarm state.	
DC supply current port BTS0 & BTS1, operating	100 mA typ. (two ports powered)
DC supply current, alarm mode, per port	150 - 300mA (programmable)



## TTA-UMG000Z\*

AISG mode (auto-selected on valid frames)	
AISG signals can be applied to either BTS0 or BTS1 port. The MHA unit switches to AISG mode when valid frames are detected on one of the BTS ports. The MHA unit is DC powered (common feed for both channels) from the port supplying AISG frames.	
AISG Version	2.0
DC supply current, total	80mA at 30V, 175 mA at 9V typical
AISG connector current rating	< 4A peak, 2 Amp continuous, pin 6
Current window alarm backup	Yes
Field Firmware upgradeable	Yes (including change to AISGv1.1)

Environmental	
Maximum Operating Temperature Range	-40 to +60 °C
Environmental	ETS 300 019
Environmental Sealing	IP67 (EN 60529)
Lightning Protection, RF & AISG ports	3 kA, 10/350us pulse (IEC 61312)
MTBF	>700,000 hours
Safety	EN 60950
EMC	3GPP TS 25.113



Mechanical	
Dimensions (excluding connectors and mounting bracket)	278 (H) x 169 (W) x 72 (D) mm see diagram
Weight	6.5 kg
Finish	Painted, light grey (RAL7035)
Connectors	DIN 7-16 (F) x 4 "Long Neck"
Mounting	Any orientation, pole / wall bracket supplied with two metal clamps for 45-178 mm diameter poles.

Model number options	
<i>Z</i> in the model number specifies the Node-B type for Current Alarm purposes.	
Value for <i>Z</i>	Node-B vendor
<b>A</b>	Alcatel-Lucent/Nortel
<b>K</b>	Nokia (WMHB compatible)
<b>H</b>	Huawei

Variants	
TTA-UMG010Z	No bracket. Two AISG connectors at bottom and top. Mounting by holes at top and bottom
TTA-UMG100Z	No bracket. One AISG connector at bottom. Mounting by holes on the sides

### Block Diagram

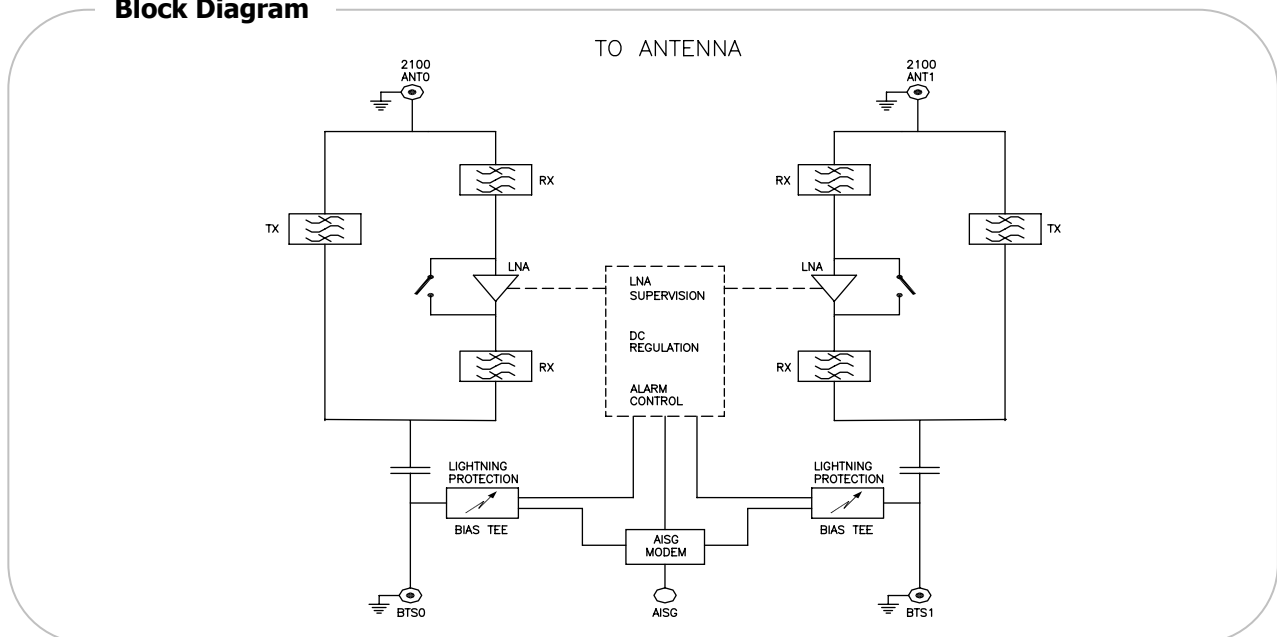

**TTA-UMG000Z\***

**Mechanical**

