

TTA-GLG0311H

UMTS900 & GSM900 combiner Type 1, active with internal twin TMA

for EGSM band



Version 2.0



- Used for co-located GSM900 & UMTS900 systems
- Integral dual duplex, twin TMA with Fail-safe bypass mode
- Maintain diversity capability on both systems
- Lightning protected, high linearity and low noise performance
- RX div ports protected against erroneous TX connection
- AISGv2.0 and current dump compatible
- AISG connector for external RET antenna control by coaxial feeder

Electrical Specifications	
Downlink (applies to GSM TX and UMTS TX paths)	
Pass band	925 - 950 MHz
Insertion Loss	0.45 dB max, 0.3 dB typ.
Return Loss, all ports	18 dB min.
EVM (4 MHz)	3% max.
Group delay variation (across passband)	5ns/200kHz max, 20ns/4MHz max
Insertion loss variation (across passband)	0.2 dB max.
Continuous Average Power	200 W max.
Peak Envelope Power	1.6kW max (into 50 ohm load, 1.6 μ s on, 2.5% duty cycle)
Isolation BTS A to BTS B port	50dB min. in downlink frequency band
Uplink Path (applies to both GSM Rx and both UMTS Rx paths)	
Pass band	880 to 905 MHz
Gain	12 \pm 1.0 dB
Gain Variation over band and temperature	\pm 1 dB max.
Noise Figure	Mid-band 1.2 dB typ, over frequency / temp 1.8 dB max
Return Loss, normal mode, all ports	18 dB min
EVM (4 MHz)	7.5% max, Main ports 5% max, Div ports
Group delay variation (across passband)	10ns/200kHz max, 40ns/4MHz max
Insertion Loss, Bypass mode	7 dB max.
Return Loss, Bypass mode, all ports	12 dB min
Output Intercept Point	+18 dBm min.
Maximum Input Power with no damage	+12 dBm (ANT ports)
General	
Impedance	50 ohms ¹ .
Isolation between ports:	
UMTS TX/RX Main to GSM RX Div	35 dB min, Rx band
GSM RX Div to UMTS TX/RX Main	20 dB min, Rx band
GSM TX/RX Main to UMTS RX Div	35 dB min, Rx band
UMTS RX Div to GSM TX/RX Main	20 dB min, Rx band
Transmission Characteristics (ANT to Tx/Rx; ANT to Rx)	Rejection relative to Rx band 50-800 MHz: 30 dB min 1050-2200 MHz: 40 dB min
Intermodulation (2x 43 dBm Tx Carriers at BTS port)	-110 dBm max. in Rx band at ANT port (measured at Rx port)
Power withstanding without damage, Div Rx ports	+46dBm max

DT 5426 - Ed C - page 1/5 - We reserve the rights to modify our products without prior notice. - Several patents pending regarding this product

¹ Performances are expressed for all ports terminated with a 50 ohms load.

TTA-GLG0311H

DC Power Supply, Alarm currents & AISG Control	
Power Supply	
The DC supply for the internal LNAs is provided through the ports labelled UMTS on the unit. If no DC is supplied on these ports, all uplink paths are set to Bypass mode.	
DC Supply Voltage	+8.5 to +30 V DC
DC ports	UMTS TX/RX Main & UMTS RX Div
Current Alarm Mode (default mode)	
DC Supply current, operating, per port	100 mA typ, 120 mA max @12V DC (two ports powered)
DC Supply current, alarm mode, per port	180 mA (other current level can be set, contact us)
AISG mode (auto-selected on valid frames)	
AISG signals can be applied to either UMTS TX/RX Main or UMTS RX div port. The unit switches to AISG mode when valid frames are detected on one of the ports. The unit is DC powered only from the port supplying AISG frames	
An AISG 8-pin connector is available on the unit for the control of RET antennas in daisy chain.	
AISG Version	2.0 (for AISGv1.1, please contact us)
DC supply current, total, typical	55 mA at 30V, 120 mA at 12V
AISG connector current rating	4A peak, 2 Amp continuous, pin 6
Current window alarm backup	Yes
Field Firmware upgradeable	Yes, by AISG download
Environmental	
Operating Temperature Range	-40 to +65°C
Environmental Sealing	IP67
Altitude	2,600 m max.
Lightning Protection	IEC61312-1 RF ports: 10/350µs, +/-2kA max AISG port: 10/350µs, +/-0.5kA max
MTBF	>500,000 hours
Mechanical	
Dimensions (excluding connectors and mounting bracket)	300 (W) x 250 (H) x 86 (D) mm see drawing
Weight	10.5 kg
Finish	Painted light grey (RAL 7035)
Connectors	6 x 7-16 DIN female "Long Neck"
Mounting	Pole / Wall, any orientation if breather is not facing upwards. Supplied with two quick release metal clamps for 45-178 mm diameter poles.



TTA-GLG0311H

Combiner block diagram

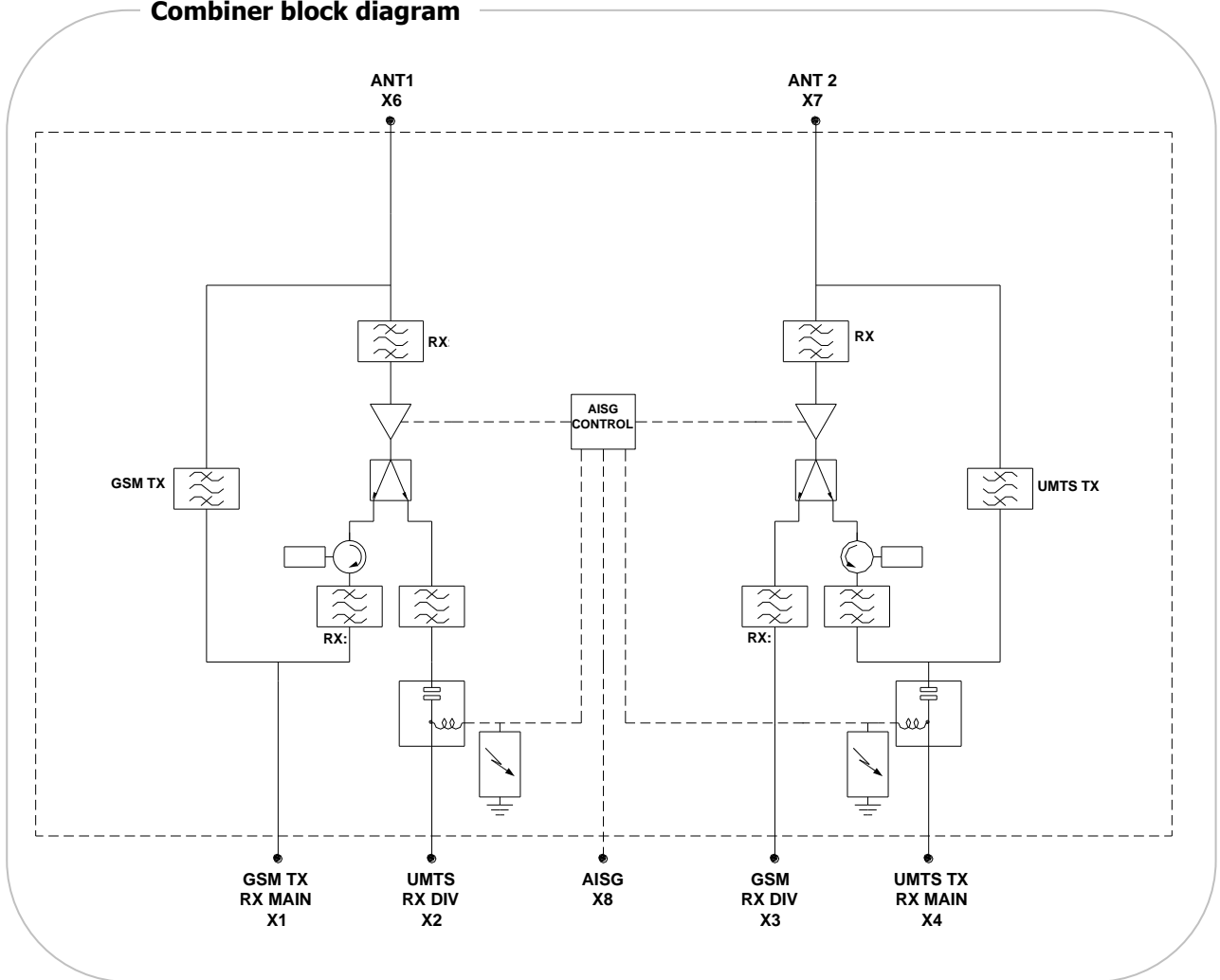

Installation & Wiring

The combiner should be installed close to the antenna to benefit from the 12dB gain of the two LNAs and their very low Noise Figure in uplink.
 The System Block Diagram provided next page explains the wiring of the combiner to the BTS and Node-B radios and to the Antenna. This diagram is provided for operation understanding only – always refer to Operator instructions for proper site installation.
 Although a cross-polarisation antenna is shown on this diagram, the combiner can be installed the same way when space diversity is used with two separate antennas.

For the installation of the jumpers between the radio units and the combiner, be particularly careful regarding location of the ports on the combiner. Always refer to the labels on the combiner to locate the ports destination. Note that we use RED rings on the GSM ports and GREEN rings on the UMTS ports. Do not connect Tx power to the Div ports.

TTA-GLG0311H

System Block Diagram

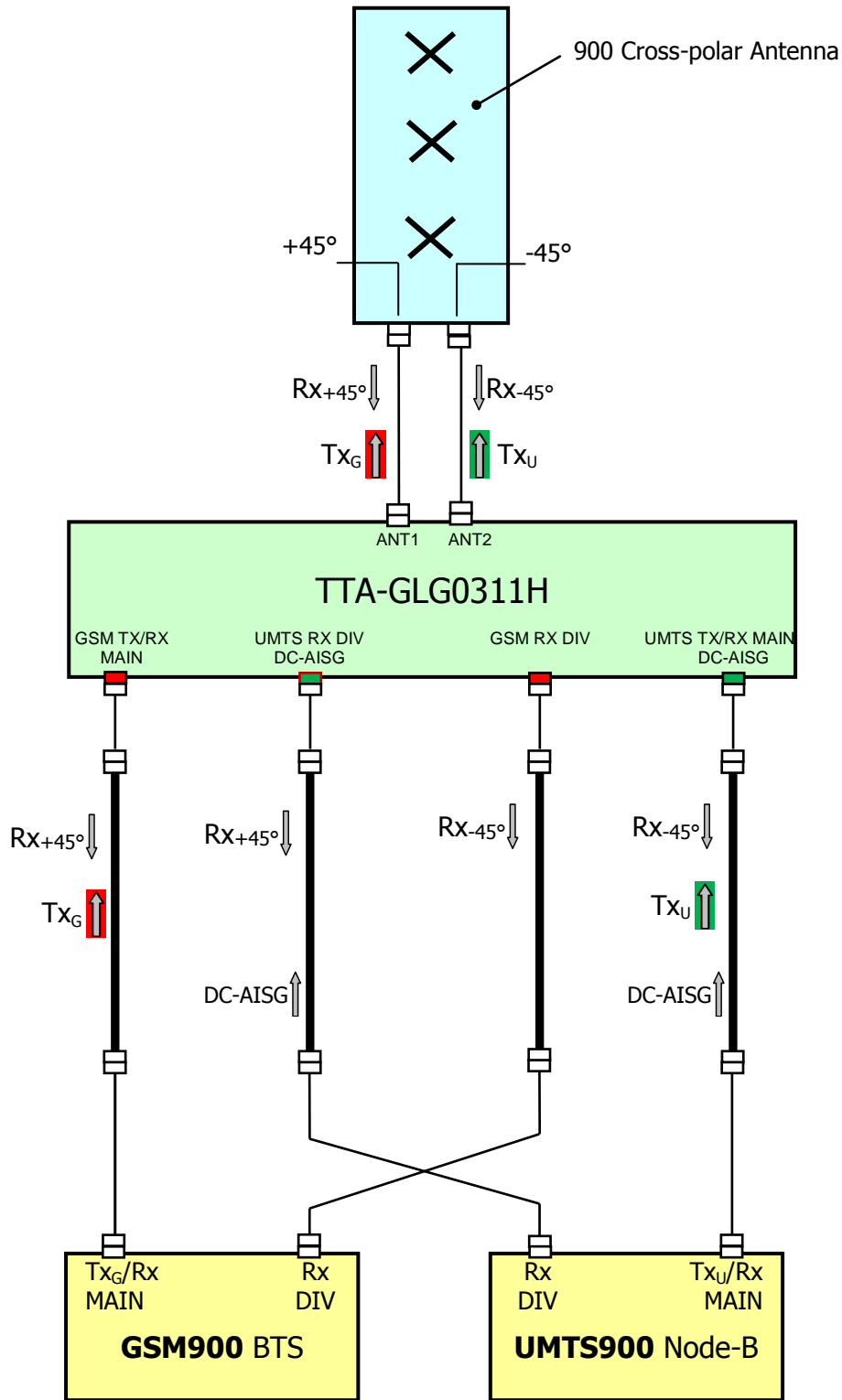

• This diagram to be read in conjunction with the "Installation & Wiring" section above.

TTA-GLG0311H

Dimensions (in mm)

