

DPX-311

UMTS900 & GSM900 combiner Type 1, passive

for EGSM band

- Allows antenna sharing by co-located GSM900 & UMTS900 systems
- Maintain diversity capability on both systems
- DC/AISG through path from UMTS Node-B ports for TMA/MHA & RET antenna control
- For indoor or outdoor use, best suited for masthead sites with TMA/MHAS
- Isolators improve RF leakage at Rx frequencies between systems
- RX Div ports protected against erroneous TX connections

Electrical Specifications

Downlink (applies to GSM TX and UMTS TX paths)

Pass-band	925 to 950 MHz
Insertion Loss	0.45 dB max at band edge, 0.35 dB typ
Return Loss	18 dB min
Power handling	100 W average, 1600 W PEP
Group delay variation across 4 MHz	20 ns max
Group delay variation across pass-band	30 ns max
Absolute Group delay max	70 ns max / 50 ns typ
EVM across 4 MHz channel	3% max

Uplink Path (applies to both GSM Rx and both UMTS Rx paths)

Pass-band	880 to 905 MHz
Insertion Loss	5 dB max at band edge, 4.2 dB typical
Return Loss	18 dB min
Group delay variation across 4 MHz	50 ns max
Group delay variation across pass-band	80 ns max
Absolute Group delay max	200 ns max / 130 ns typ

General

Impedance	50 ohms ¹
Isolation between ports:	
GSM TX/RX Main to UMTS RX Div	35 dB min, Tx band / 35 dB min, Rx band
GSM TX/RX Main to GSM RX Div	35 dB min, Tx band / 35 dB min, Rx band
GSM TX/RX Main to UMTS TX/RX Main	35 dB min, Tx band / 35 dB min, Rx band
UMTS RX Div to GSM TX:RX Main	35 dB min, Tx band / 20 dB min, Rx band
UMTS RX Div to GSM RX Div	35 dB min, Tx band / 35 dB min, Rx band
UMTS RX Div to UMTS TX/RX Main	35 dB min, Tx band / 35 dB min, Rx band
UMTS TX/RX Main to GSM RX Div	35 dB min, Tx band / 35 dB min, Rx band
GSM RX Div to UMTS TX/RX Main	35 dB min, Tx band / 20 dB min, Rx band
Attenuation, ANT to RX Div (GSM or UMTS)	40 dB min, Tx band
Inter-modulation: Reflected at BTS Port, Rx band	<-150 dBc with 2 x 20 W carriers

DC & Signalling (for optional TMA installed on the antenna line)

DC Paths	UMTS TX/RX Main to ANT2 port, UMTS RX Div to ANT1 port
Pass-band	DC to 3 MHz (AISG feedthrough)
Insertion loss	1 dB max
Return loss	12 dB with DC/signalling
Input voltage / Current capability	± 33 V max / 2 A max
Surge protection	Gas arrestor fitted on each port. M6 earth stud fitted on the unit

Environmental

Operating Temperature Range	-40°C to +65°C
Operating Altitude	2000 m max
IP rating	IP67 (housing)
RoHS compliant	Yes



¹ Performances are expressed for all ports terminated with a 50 ohms load.

DPX-311

Mechanical	
Dimensions (excluding connectors and mounting bracket)	250 (H) x 300 (W) x 86 (D) mm (see drawing on last page)
Weight	10 kg
Finish	Painted light grey (RAL 7035)
Connectors	DIN 7-16 (F) x 6 "Long Neck"
Mounting	Bracket for pole/wall mounting fitted to the unit. Delivery includes two metal clamps for 45-178 mm diameter poles.

Installation & Wiring

The combiner can be installed any where between the radio units (BTS and Node-B) and the antenna, but it will usually be installed close to the radio units. It is usual also to install a TMA close to the antenna to increase the system sensitivity and to compensate for the combiner losses in the uplink path. DC power (and AISG) for the installed TMA will be provided by the UMTS Node-B through the combiner DC-pass capability.

The System Block Diagram provided next page explains the wiring of the combiner to the BTS and Node-B radios and to Antenna. This diagram is provided for operation understanding only – always refer to Operator instructions for proper site installation.

Although a cross-polarisation antenna is shown on this diagram, the combiner can be installed the same way when space diversity is used with two separate antennas.

For the installation of the jumpers between the radio units and the combiner, be particularly careful regarding location of the ports on the combiner. Always refer to the labels on the combiner to locate the ports destination. Note that we use RED rings on the GSM ports and GREEN rings on the UMTS ports. Do not connect Tx power to the Div ports.

Combiner Block Diagram

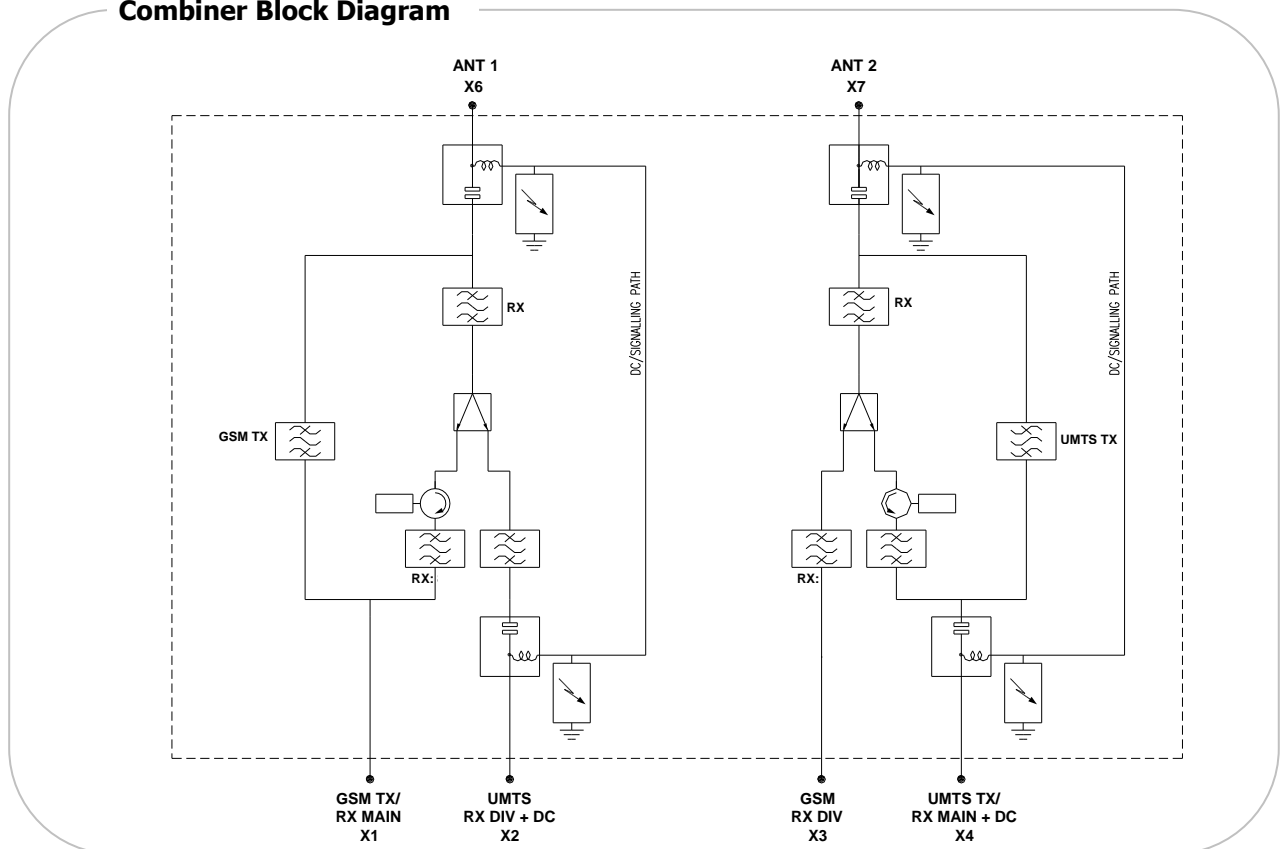

DPX-311

System Block Diagram

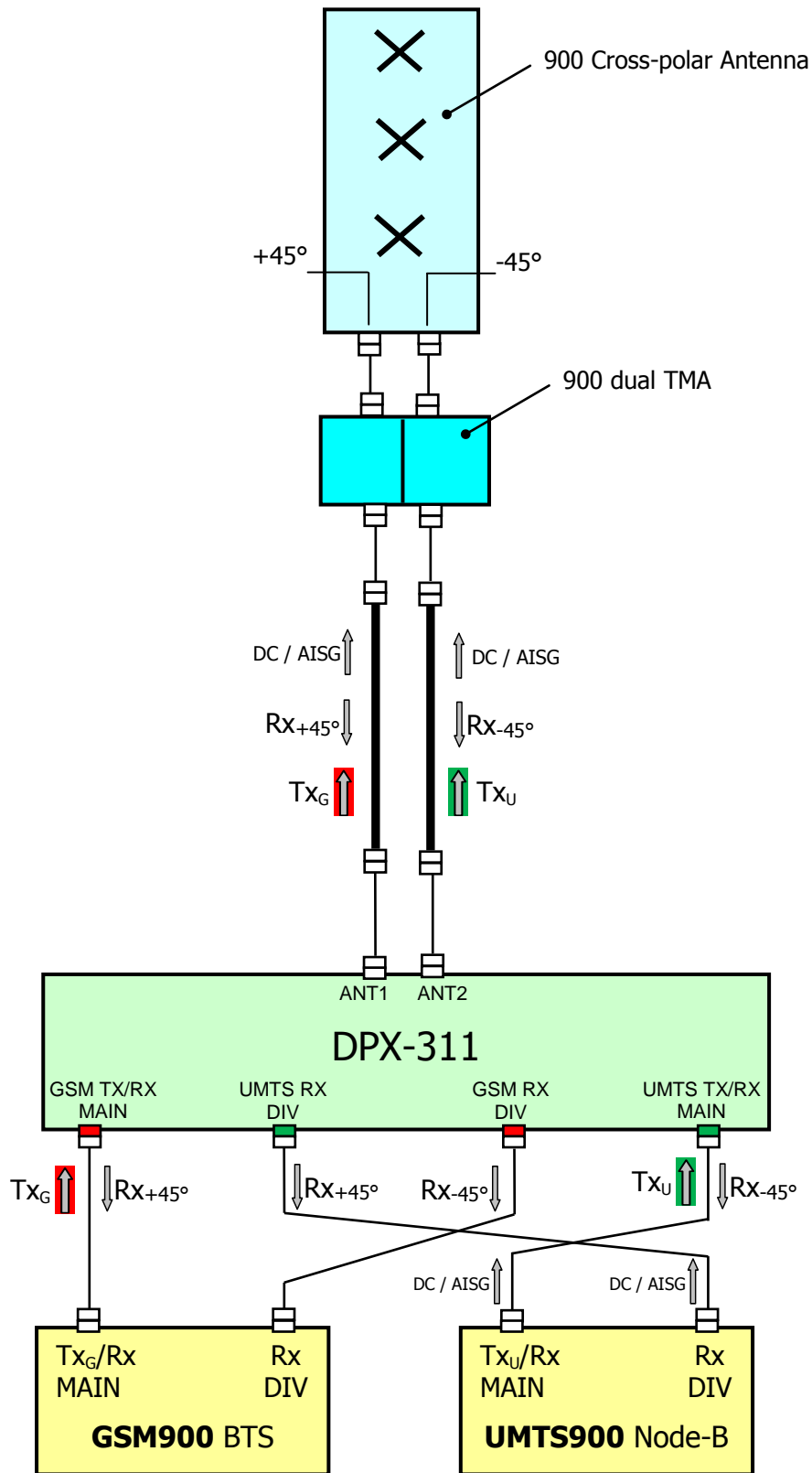

• This diagram to be read in conjunction with the "Installation & Wiring" section above.

Dimensions (in mm)

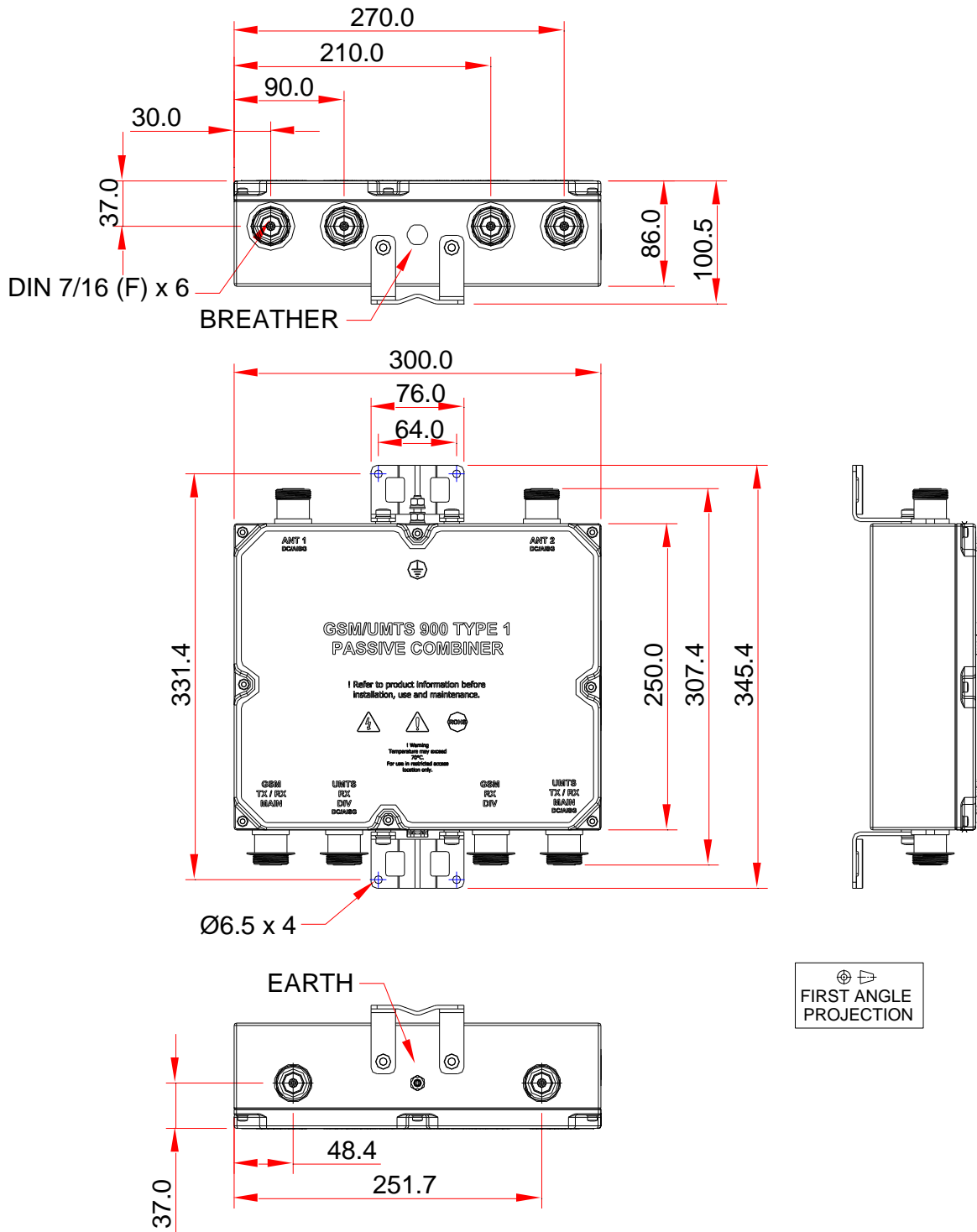

DT 5410 - Ed C - page 4/4 - We reserve the rights to modify our products without prior notice.. - Several patents pending regarding this product.